

# DeRoNa 360°

proximal femur derotation nail

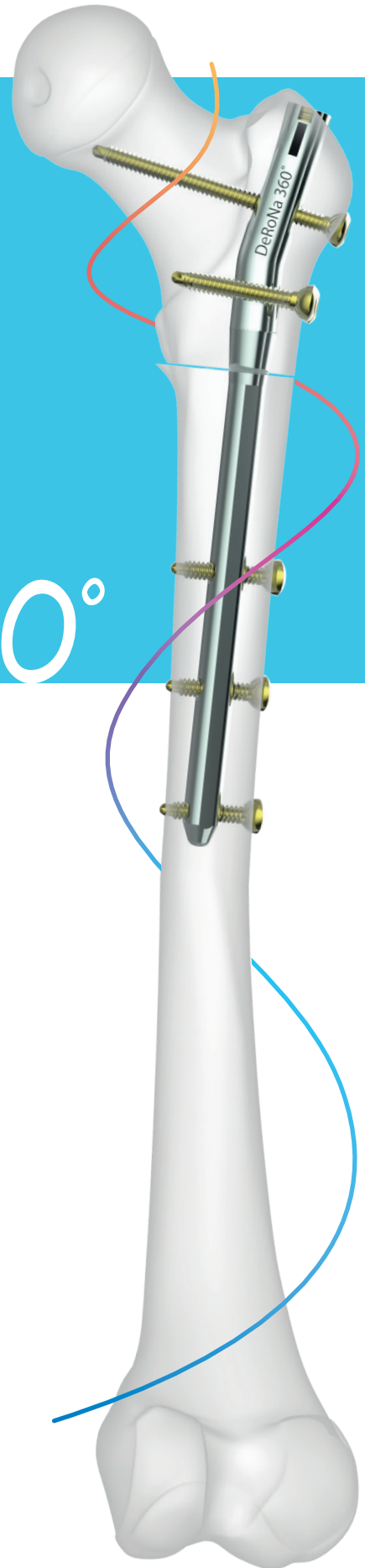

**peditst**

# Introduction

DeRoNa 360° (Proximal Femur Derotation Nails) is an innovative proximal femur nail that is designed for pediatric orthopedics and traumatology applications.

The DeRoNa 360° Nail consists of 2 separate (proximal and distal) parts connected with connection bolt. It is fixed as a rigid nail and allows a controlled rotational correction.

The application of DeRoNa 360° Nail from the lateral trochanteric entry point, minimizes the risk of damaging the vascular structure and soft tissues near the piriformis fossa. This prevents muscle weakening, especially by accelerating the rehabilitation process of the children with neurological diseases.

## Index

- 1 Introduction
- 1 Indications
- 2 Features
- 5 Surgical Technique
- 12 Nail Extraction
- 13 Set Detail

## Indications

DeRoNa 360 is designed for proximal femur derotation osteotomy treatments, proximal region fractures, malunion, nonunion and deformities in the child age.

### Warning:

This descriptive catalog is not sufficient as being unaided for proper use of the products intraoperatively. It is highly recommended that implantation and instrument sets must be used by a surgeon who is trained-experienced about the product performances and usage.

## Features

DeRoNa 360° is applied from the lateral trochanteric entry point.

The DeRoNa 360° has 12° of valgus angle. The length of the proximal slope is 32 mm.

DeRoNa 360° consists of proximal and distal parts. Proximal slope of the nail is designed to make the easiest entry in the sagittal and coronal plane.

Proximal and distal components are loosened for controlled rotational correction to provide the proximal femur anteversion correction. Distal and Proximal components are connected with the connection bolt to form the rigid nail structure.

The square shaped proximal part is designed to increase the rotational stability in the proximal femur.

The proximal part of DeRoNa 360° has three different width dimensions (10-11-12 mm).

The locking screws can be applied from 3 different positions of the proximal part.

The locking screws are available in 20 different sizes from 18 to 70 mm.

The distal component is available in three sizes (100-125-150 mm) and three different diameters (Ø 8-9-10mm).

DeRoNa 360° has 1 piece on a 100 mm long distal component, 2 pieces on 125 mm, and 3 static locking holes on the 150 mm long component.

End Caps are available in four different sizes as 0-5-10-15 mm.

The surgical instruments (nail guides, reamers, inserters, etc.) are placed in their trays in a container suitable for sterilization.

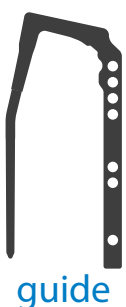
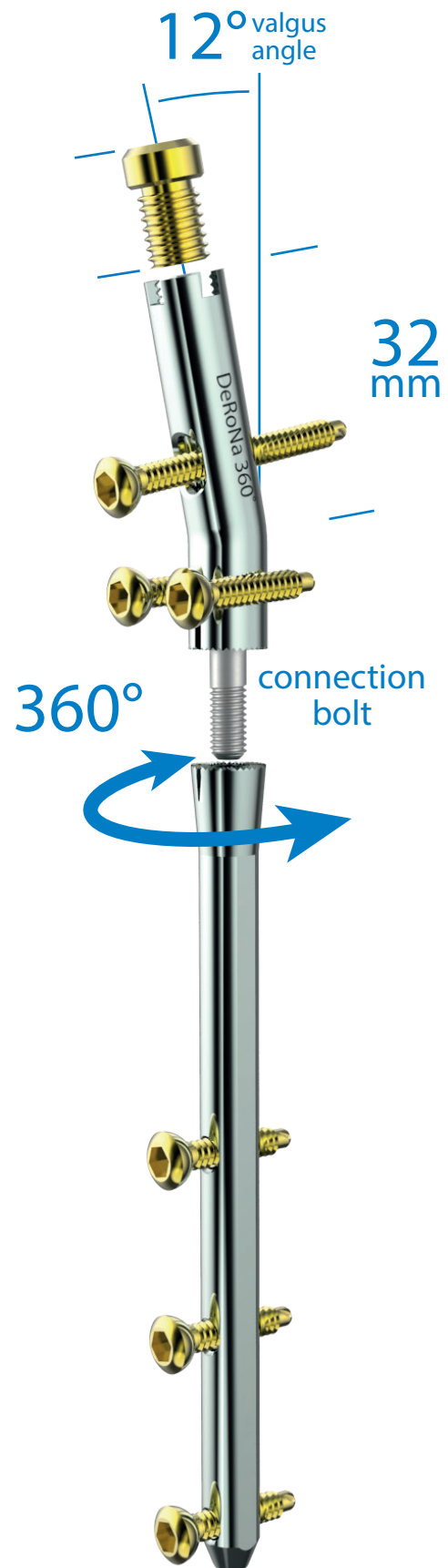



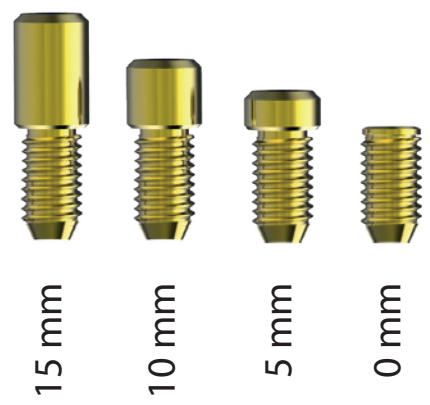
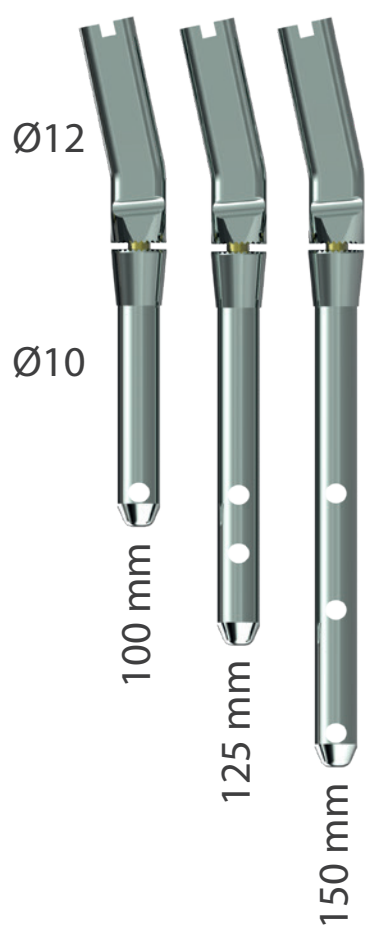
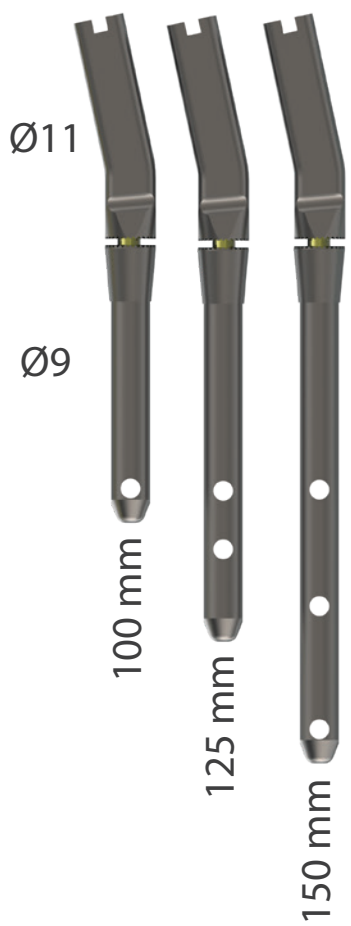
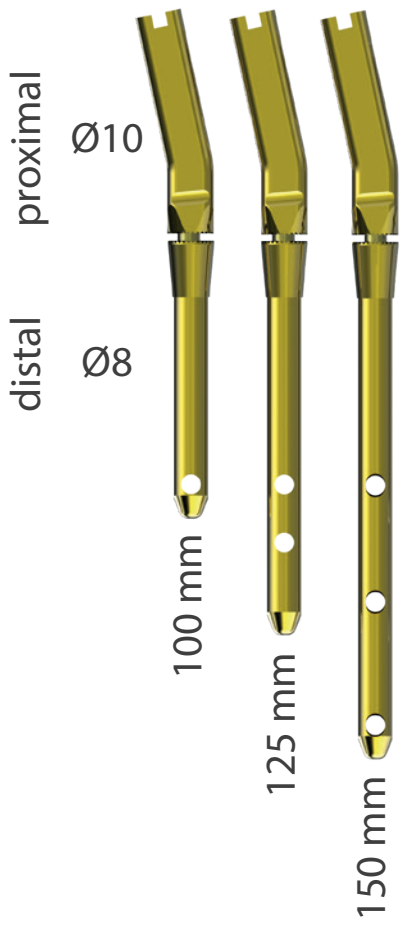

# Surgical Technique

## 1 NAIL ENTRY POINT

The proximal part of DeRoNa 360° has 12° of lateral angle. Due to this angled design, the entry point becomes important.

The nail entrance should be 2 mm lateral to the trochanter major tip. For this purpose, the 2x300 mm Guide Wire is placed in the middle of the medullary canal in the lateral direction and the 2 cm distal of the trochanter minor is targeted in the anterior-posterior view. Guide Wire can be used with Ø 2/12 K-Wire Guide.

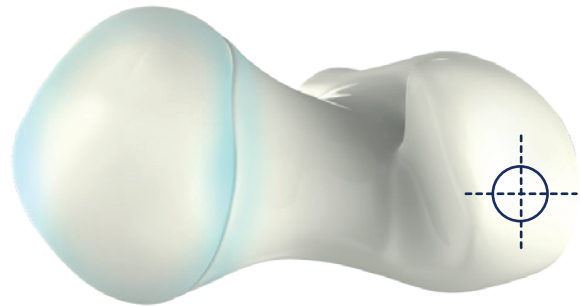

## 2 OPENING ENTRY POINT

The reaming process is carried out over the Guide Wire with specially designed cannulated reamers. The reaming is started with the smallest reamer size and reamed to the planned nail size (Cannulated reamer diameters are 10 mm, 11 mm and 12 mm). Reaming should only be applied in the trochanteric region to avoid damaging the medullary canal. (Reamers can be used with T-Holder or Motor)

Even though the reamer is in place, 1.5x120 mm K-Wire is placed in the direction of the femoral neck anteversion. The second K-Wire is placed in the supracondylar region and the wires for rotational correction are used as a guide.

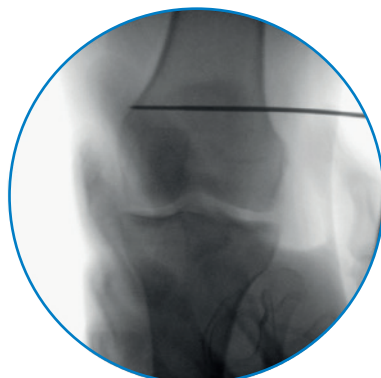
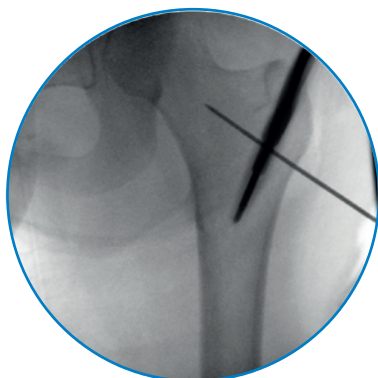

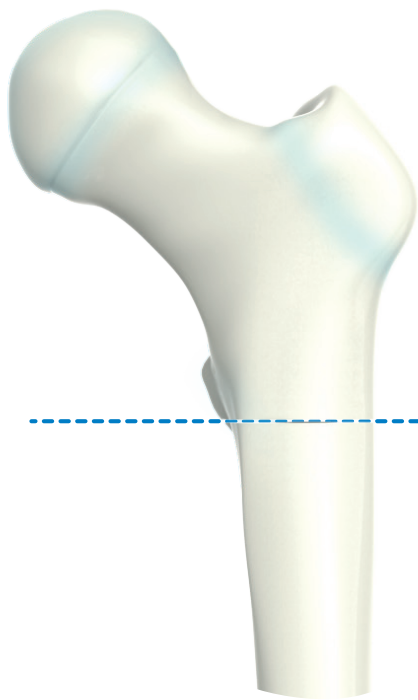

osteotomy line

### 3 OSTEOTOMY

At the trochanter minor level, approximately 3 cm incision is made. The osteotomy is planned to be located approximately 10 mm distal of the trochanter minor. Osteotomy should be applied perpendicularly to the long axis of the bone. Otherwise, rotational correction might be a problem.



### 4 MEDULLARY CANAL PREPARATION

Reaming is not recommended at distal part of osteotomy. However, if reaming will be applied, there are three different diameter Flexible Reamers as 10.5, 11.5 and 12.5 mm in the set. Extreme reaming in children must be especially avoided.

\* Flexible Reamers are cannulated, can be used with  $\varnothing$  2.5X600 Guide Wire.

\* Flexible Reamers have laser marks to see how far they are in the tissue protector.



## 5 NAIL-INSERTION HANDLE INSTALLATION

The laser mark on the proximal of the nail is mounted with matching the laser mark on the Insertion Hand. The Connection Screw is cannulated and attached with Allen Wrench.

NOTE: Excessive tightening of the Connection Bolt may cause bolt breakage. Complete session and coherence are sufficient.

Alignment rods must be fitted to the proper distal locking holes via the insertion handle. The connection bolt and nail components should be properly installed. The marks on the proximal-distal joint of the nail should be matched.

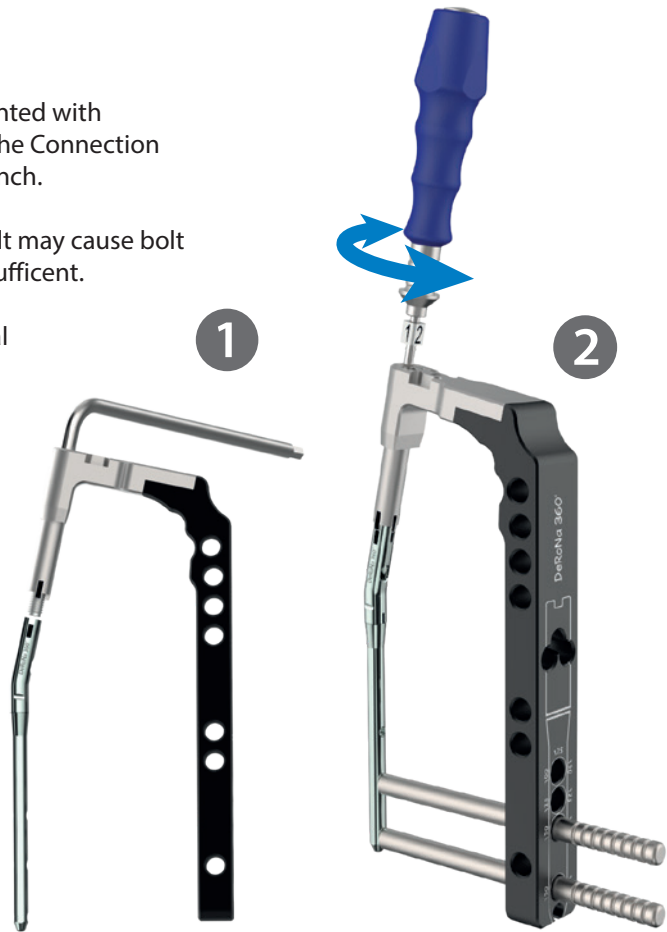

## 6 NAIL INSERTION

The nail mounted on the insertion handle is inserted into the intramedullary through the entrance hole at the trochanteric region. The insertion should be adjusted to the proximal locking screw level. The Screw Level should be at distal of trochanteric apophysis.

The proximal of the nail should remain in the apophysis in the final position.

The nail joint mustn't not be in the osteotomy line, it is essential to prevent nail failures.

If hammering is needed during nail insertion; Insertion Knob can be used with light hammer strokes. Insertion Knob must be mounted on the Insertion Handle. Hitting on Insertion Handle is never recommended.

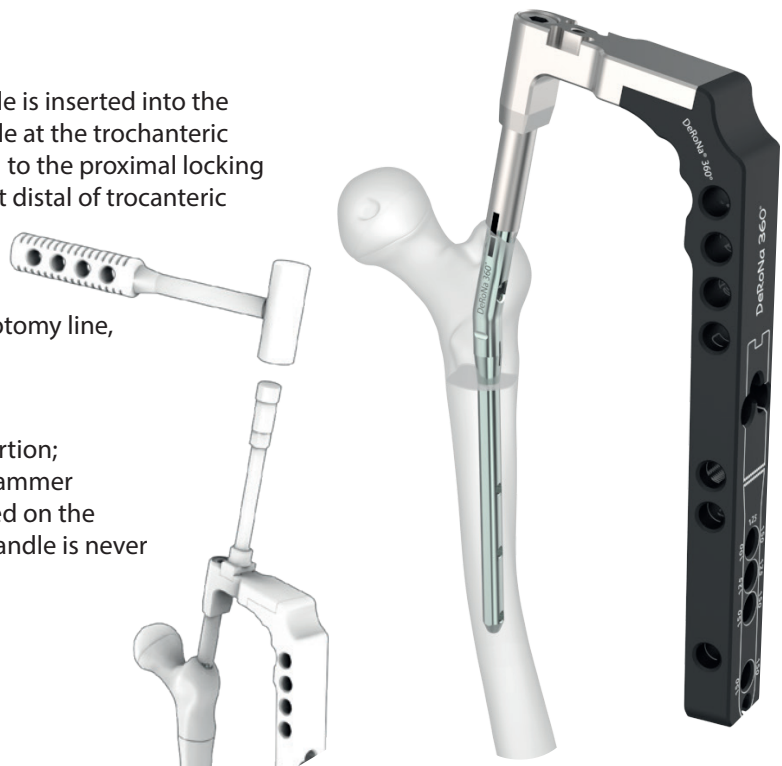



## 7 DISTAL LOCKING

Distal locking screws are inserted with appropriate procedures. Screw Sleeve and Trocar's bone cortex contacts are provided with skin and subcutaneous incision. After removing the Trocar, Drill Guide is attached. Drilling is done by Ø3.2X300 mm Drill. Screw length is determined by using Depth Gauge. The locking screw of the appropriate length is inserted with the Screwdriver (4X9x150 mm). According to the length of the nail, distal locking screws could be applied to 2nd and 3rd static holes with the same way.

The laser marks on the screwdriver enables to observe the insertion level of the screw.



## 8 PROXIMAL LOCKING

The proximal locking should be done after completing the distal locking. On the proximal component, there are two transverse directional polar screw locking curves and oval locking hole. Polar screws pass through posteriorly and anteriorly of the nail. Polar screws are preferably used to increase stability during the rotation correction. At this stage, the locking screw is not used inside the oval hole, otherwise the rotation system will be locked.



## 9 DEROTATION MEASURER INSTALLATION

Derotation Mesurer Guide is mounted to distal of Insertion Handle. 2x300 mm K-Wire is sent to the bone inside of the Mesurer Guide. Derotation Mesurer Guide is removed and Derotation Mesurer is applied. The angular correction can be followed via K-Wire and Derotation Mesurer.





## 10 DEROTATION CORRECTION

The Connection Bolt is loosened by a half-turn with the numbered Screw Driver Cross Tip 5.0 mm. (Screw Driver Cross Tip 5.0 mm is marked with 1-2-3-4 numbers.) While Loosening procedure, attention must be observed to the numbers on it. For instance, according to the direction of view if number 1 is seen at the screwdriver, it should be loosen since number 3 in order to make a half turn of loosening.

When the connection screw is loosened; Each notch in the rotation movement between the proximal and the distal part provides 10° rotation. Rotation can be felt as a click sound during application. The rotational correction according to preoperative planning is made by following with Derotation Measurer. After the derotation correction, the connection bolt is tightened with the Torque Screwdriver. The combination between the proximal and distal parts should be clearly seen in the fluoroscopy.



## 11 PROXIMAL LOCKING

The locking screw can be applied from the oval hole towards the femur after correction. The Insertion Handle and other instruments are removed after the placement of the nail.

## 12 INSERTION END CAP

There are four different lengths for the End Caps as 0- 5-10-15 mm. When installing the end cap, it must be considered to be on the same axis with the proximal nail and should pay attention in order to ensure a full settlement.



Finally, the screw placement is confirmed by anterior-posterior and lateral scopy control. The extremity length, alignment, derotation, foot and knee, patella posture are checked.



# 13 NAIL EXTRACTION

After removing the End Cap, the Nail Extractor is attached to the nail.  
After removing the proximal and distal locking screws, the hammer strokes are applied to the Nail Extractor for removing.



# Set Detail

code	description	qty
80220210010	DERONA 360 8x100 MM	2
80220220010	DERONA 360 8x125 MM	2
80220250010	DERONA 360 8x150 MM	2
80220210011	DERONA 360 9x100 MM	2
80220220011	DERONA 360 9x125 MM	2
80220250011	DERONA 360 9x150 MM	2
80220220012	DERONA 360 10x100 MM	2
80220250012	DERONA 360 10x125 MM	2
80220000000	DERONA 360 10x150 MM	2
83021800053	DERONA NECK LOCK IMPLANT 11 MM	2
83021000053	DERONA NECK LOCK IMPLANT 12 MM	2
83021600053	DERONA NECK LOCK IMPLANT 10 MM	2
81520010011	DERONA CONNECTION BOLT	6
00000802220	DERONA SCREW BOX	1
22124040018	CORTEX SCREW FOR NAILS TI Ø4.0X18 MM	3
22124040020	CORTEX SCREW FOR NAILS TI Ø4.0X20 MM	3
22124040022	CORTEX SCREW FOR NAILS TI Ø4.0X22 MM	3
22124040024	CORTEX SCREW FOR NAILS TI Ø4.0X24 MM	3
22124040026	CORTEX SCREW FOR NAILS TI Ø4.0X26 MM	3
22124040028	CORTEX SCREW FOR NAILS TI Ø4.0X28 MM	3
22124040030	CORTEX SCREW FOR NAILS TI Ø4.0X30 MM	3
22124040032	CORTEX SCREW FOR NAILS TI Ø4.0X32 MM	3
22124040034	CORTEX SCREW FOR NAILS TI Ø4.0X34 MM	3
22124040036	CORTEX SCREW FOR NAILS TI Ø4.0X36 MM	3
22124040038	CORTEX SCREW FOR NAILS TI Ø4.0X38 MM	3
22124040040	CORTEX SCREW FOR NAILS TI Ø4.0X40 MM	3
22124040044	CORTEX SCREW FOR NAILS TI Ø4.0X44 MM	3
22124040048	CORTEX SCREW FOR NAILS TI Ø4.0X48 MM	3
22124040052	CORTEX SCREW FOR NAILS TI Ø4.0X52 MM	3
22124040056	CORTEX SCREW FOR NAILS TI Ø4.0X56 MM	3
22124040060	CORTEX SCREW FOR NAILS TI Ø4.0X60 MM	3
22124040064	CORTEX SCREW FOR NAILS TI Ø4.0X64 MM	3
22124040068	CORTEX SCREW FOR NAILS TI Ø4.0X68 MM	3
22124040070	CORTEX SCREW FOR NAILS TI Ø4.0X70 MM	3
0209001	END CAP SCREW BOX	1
85020000000	DERONA END CAP 0 MM	2
86020000005	DERONA END CAP 5 MM	2
86020000010	DERONA END CAP 10 MM	2
86020000015	DERONA END CAP 15 MM	2
00000802210	DERONA IMPLANT TRAY	1

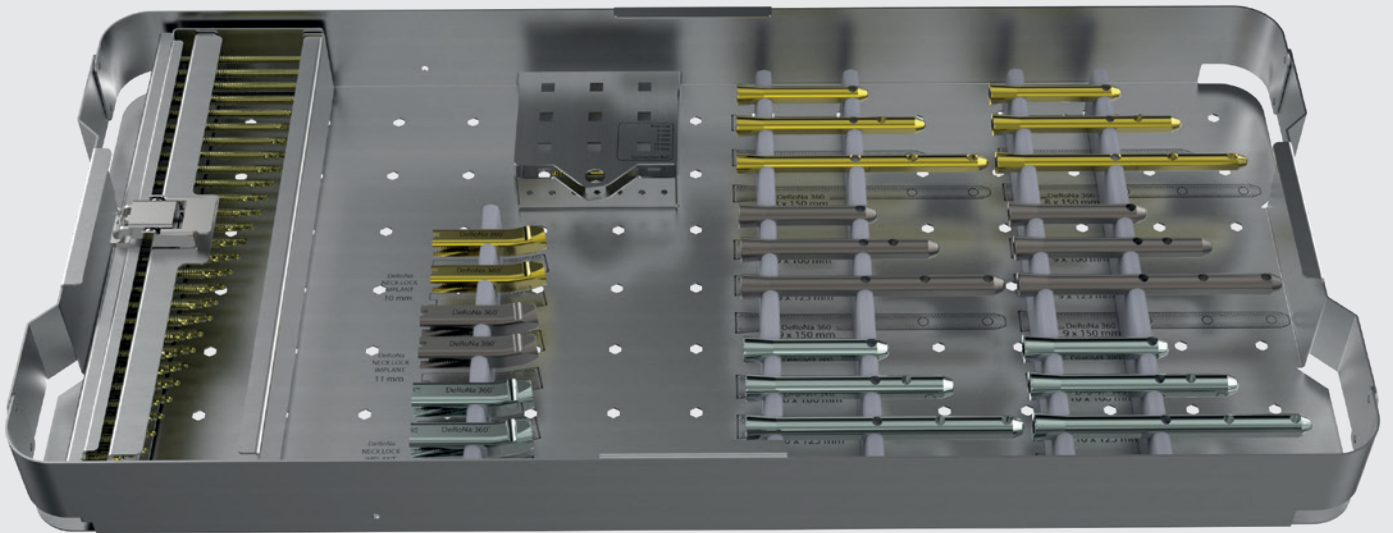



code	description	qty
08022001065	REAMER 6.5X10X220 MM	1
08022001165	REAMER 6.5X11X220 MM	1
08022001265	REAMER 6.5X12X220 MM	1
08022011012	PROTECTION SLEEVE 12 MM	1
08022000060	K-WIRE GUIDE Ø2/12 MM	1
01610000105	FLEXIBLE REAMER Ø 10.5	1
08050000115	FLEXIBLE REAMER Ø 11.5	1
08050000125	FLEXIBLE REAMER Ø 12.5	1
01193000023	T QUICK HANDLE	1
00000802230	DERONA 1.INSTRUMENT TRAY	1



code	description	qty
08022001000	DERONA INSERTION HANDLE	1
08022001020	DERONA NAIL HOLDER CONNECTION SCREW	2
04015000050	ALLEN WRENCH Ø 5 MM	2
02000409150	SCREW DRIVER QUICK HEX. TIP 4X9x150 MM	2
2060406245	CANNULATED SCREWDRIVER Ø 4.0 MM	1
08022015035	SCREWDRIVER CROSS TIP 5.0 MM	2
02010101002	SOFT SCREW DRIVER QUICK LARGE	1
01191000040	SCREW DRIVER TORQUE 3NM	1
08022000020	DERONA SCREW SLEEVE	1
08022000030	DERONA DRILL GUIDE	1
08022200080	DERONA TROCAR 8 MM	1
08022000050	ALIGNMENT PIN	2
08022002508	DEROTATION MEASURER	2
08022000040	DEROTATION MEASURER GUIDE	1
00000802240	DERONA 2.INSTRUMENT TRAY	1

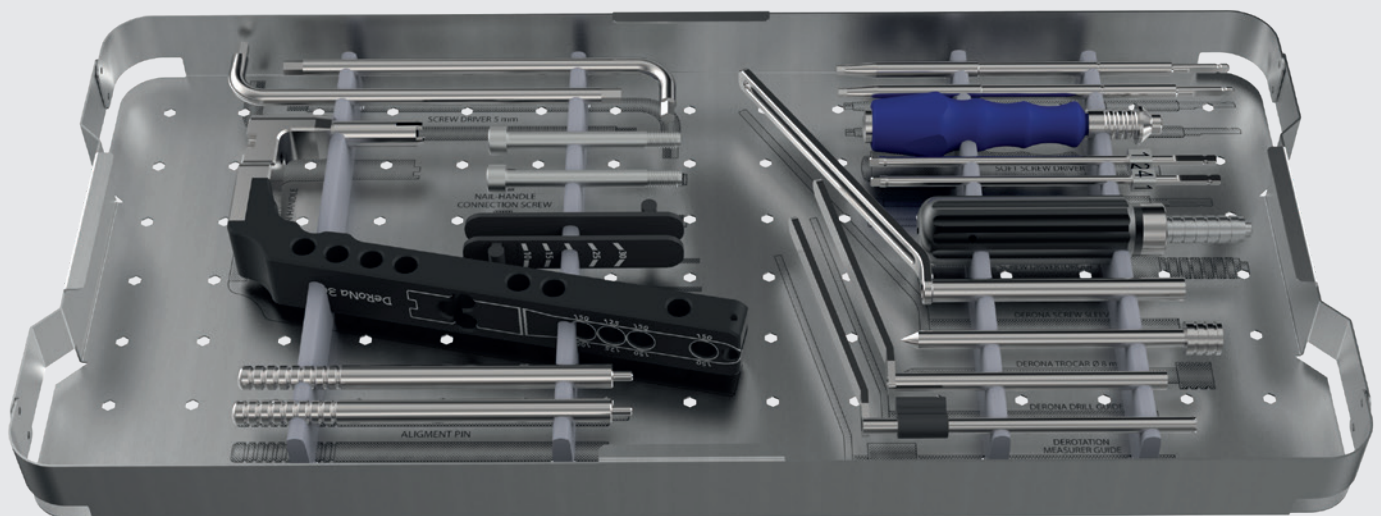

code	description	qty
04551080310	K-WIRE TUBE Ø10XØ8X310 MM	2
23410300130	KIRSCHNER WIRE TROCAR POINT 3X300 MM	3
23412300020	KIRSCHNER WIRE TREADED POINT 2X300 MM	2
02262508545	BONE DRILL 4.5X85X250 MM	2
01610030032	GRADUATED DRILL BIT Ø3.2X300 MM	2
04551208160	K-WIRE TUBE Ø12XØ8X160 MM	1
23422120015	KIRSCHNER WIRE THREADED POINT TI 1.5X120 MM	4
02001400100	DEPTH GAUGE - HIN PROX. SCREW LENGTH	1
03310000001	T-HANDLE JACOBS CHUCK-KEY	1
08050000200	T-HANDLE MALE NAIL INSERTER	1
01193002009	BONE HAMMER - MEDIUM	1
01610003000	SURGICAL RULER S.S 300 MM	1
08044000012	WRENCH 12 MM	1
08022001030	DERONA INSERTION KNOB	1
08061000006	FEMUR INTRAMEDULLARY NAIL EXTRACTOR	1
01195001009	HINGED SLOTTED HAMMER LARGE	1
00000802250	DERONA 3.INSTRUMENT TRAY	1
00560270125	CONTAINER 560X270X125 MM	2
00260250600	PFN KIRSCHNER WIRE GUIDE Ø2.5X600	1

